

# ROTARY LIFT

P.O. Box 1560 Madison, IN. 47250  
 WORLD LEADER IN LIFT SYSTEMS  
 A **DOVER** INDUSTRIES COMPANY

## MODELS: SPOA7 & SPOA9 PARTS BREAKDOWN (For SPOA7 & SPOA9-100 to -199 Lifts) (Non-Seismic Lift)

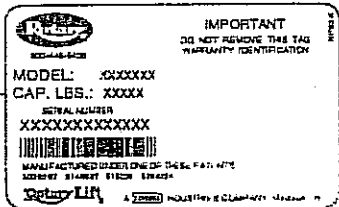
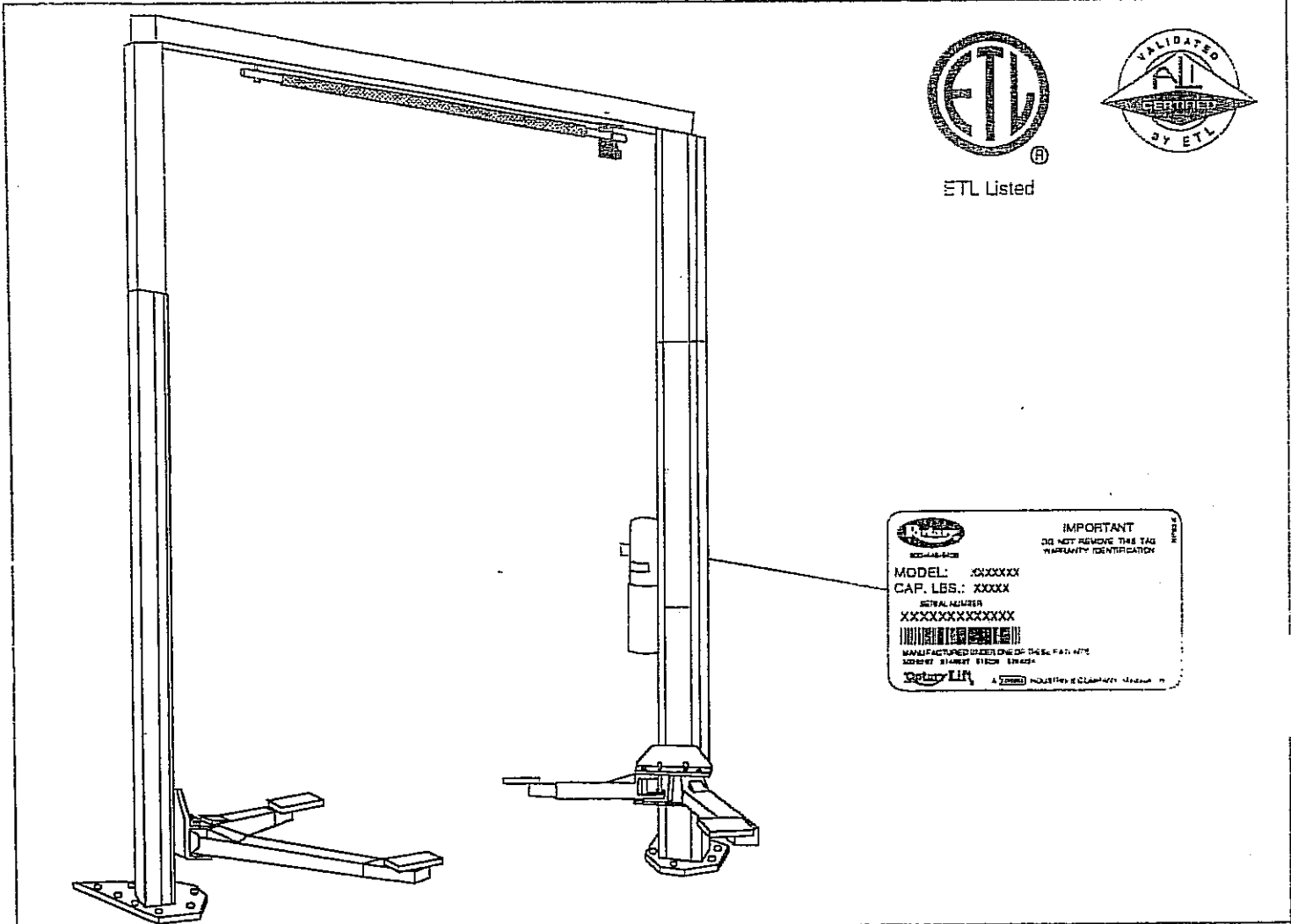

**IMPORTANT:** When ordering parts or requesting service always give exact model and power unit serial number. Model number is shown on nameplate attached to base of Power Unit column. Power unit serial number is located on side of power unit reservoir.

**NOTES:**

- New power unit models are now being used. Models are as follows:

SPOA7 single phase = P750 replaced previous model P650.  
 SPOA7 three phase = P751 replaced previous model P651.

SPOA9 single phase = P702 replaced previous model P602.  
 SPOA9 three phase = P704 replaced previous model P604.

**OWNERS RECORD**

Complete information at right and keep in a safe place.

Date Installed \_\_\_\_\_ / \_\_\_\_\_ / \_\_\_\_\_

Installed In Bay # \_\_\_\_\_

Std. Pwr.Unit Serial # \_\_\_\_\_ Model # \_\_\_\_\_

3 ph. Pwr. Unit.Serial # \_\_\_\_\_ Model # \_\_\_\_\_

Lift Serial # \_\_\_\_\_

Model No# \_\_\_\_\_

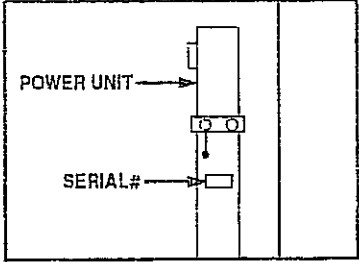

**NOTE:** For Replacement Parts - See Your Nearest Rotary Parts Distributor

## SPOA7/9 PARTS LIST

ITEM NO.	DESCRIPTION	SPOA7 PART NO.	SPOA9 PART NO.	ITEM NO.	DESCRIPTION	SPOA7 PART NO.	SPOA9 PART NO.
1	L.H. Column Weldment	N73	N73	38	Spring Pin, 1/4" dia. x 1 1/2 lg. (Stainless)	14427	14427
2	R.H. Column Weldment	N74	N74	39 †	† Adjustment Bolts & Washers	See Below	See Below
3	Column Extension	N45	N410	40	Gear Bolts 3/8"-16NC x 1 1/2"	40200	40200
4	Left Hand Carriage Yoke Weldment	N82	N84		HHCS Grade 5		
5	Right Hand Carriage Yoke Weldment	N83	N85	41	3/8" Spring Washers	40818	40818
6	Left Front Outer Arm	FJ7647-1	FJ7661-1	42	Restraint Gear	FJ7750	FJ7750
7	Right Front Outer Arm	FJ7648-1	FJ7660-1	43	Slider Block	FJ7360	FJ7360
8	Left Rear Outer Arm	FJ7649-1	FJ7662-1	44	3/4" Concrete Anchor (14 Req'd)	FJ7380	FJ7380
9	Right Rear Outer Arm	FJ7649-1	FJ7662-1	45	1 1/2" O.D. x .760-.770" I.D. x .045" Thick Mach. Bushing	41388	41388
10	Hydraulic Cylinder	FJ7664	FJ7664				
11	Power Unit	See "NOTES" On Front Cover		46	1/4"-20NC x 2" HHCS	40109	40109
12	Power Unit Hose	FJ837	FJ837	47	1/4" — 20NC Insert Lock Nut	41423	41423
13	Branch Tee	FJ7668	FJ7668	48	1/8" x 1" Lg. Cotter Pin	41200	41200
14	5/16" - 18NC x 3/4" Lg. HHCS, External Tooth Lockwashers (5pcs.) & Hex Nuts	40224	40224	49@@	Limit Switch Assembly	FJ7613 @@	FJ7613 @@
15 *	* Front Inner Arm Assembly	FJ7256-2	FJ7491-6	50	Switch Bar Assembly	FJ7613-2	FJ7613-2
16 *	* Rear Inner Arm Assembly	FJ7150-2	FJ7493-6	51	R.H. Latch Sheave Bracket	FJ7444-14	FJ7444-14
17	3/8" 16NC x 5/8" Lg. HHCS Gr.8	40155	40155	52	R.H. Overhead Weldment	N42-1	N42-1
18	3/8" Internal Tooth Lockwasher	40843	40843	53	3/8" — 16NC x 3/4" Long HHCS	40134	40134
19	High Step Adapter	FJ671-1	FJ671-1	54	3/8" Flat Washer	40820	40820
20	Low Step Adapter	FJ671-2	FJ671-2	55	Overhead Hose	FJ838	FJ839
21	Optional Rubber Adapter	FJ697	FJ697	56	Equalizer Cable Assembly	FJ7449	N33
22	Adapter Pin	FJ671-3	FJ671-3	57	L.H. Overhead Weldment	N41-1	N41-1
23	3/32" Hog Ring For 1/2" Shaft (8 Req'd)	FJ671-6	FJ671-6	58	Locking Latch Cable Assembly	FJ7594-1	FJ7594-1
24	Adapter Swivel Pin	FJ79-6	FJ79-6	59	3/8" — 16NC x 1" Flanged HHCS	40144	40144
25	Bleeder Screw (specify manufacturer)	2 REQ'D	2 REQ'D	60	3/8" — 16NC Flanged Locknut,	40664	40664
26	Carriage Bumper (2 Req'd)	FJ7391-2	FJ7391-2	61	Sheave Shaft	FJ7444-8	FJ7444-8
27	Arm Pin	FJ7834	FJ7838	62	Bracket	FJ7613-1	FJ7613-1
28	Approach Bumper (Door-18" Lg-2 Req'd)	FJ7391-1	FJ7391-1	63	1/4"-20NC x 3/4" HHCS	40104	40104
29	1/2" — 13NC Hex Lock Nut	40703	40703	64	L.H. Latch Sheave Bracket	FJ7445-6	FJ7445-6
30	3/16" x 2" Long Cotter Pin	41250	41250	65	Locking Latch Sheave	FJ7322	FJ7322
31	Truarc #5304-75 Klipring for 3/4" Shaft	41411	41411	66	Truarc Klip #5304-37 for 3/8" Shaft	41410	41410
32	Sheave	FJ7116-1	FJ7116-1	67	Hose Clip (4 Req'd)-Overhead	FJ7206	FJ7206
33	Wheel Spotting Dish Kit	FF729	FF729	68	Hose Clip (6 Req'd)-Columns	FJ7499	FJ7499
34	Actuator Pin	FJ7646-1	FJ7656-1	69	#10 — 24NC x 3/8" Lg. Slotted HHTS (For Overhead)	40033	40033
35	Retaining Ring	FJ7646-2	FJ7646-2		5/16" — 18NC x 3/8" Lg. Slotted PHMS (For Columns)	40227	40227
36	Arm Restraint Spring	FJ7813-10	FJ7656-2	70	1/4"-20NC X 3/4" LG.HHCS	40099	40099
37	120T Gear Block	FJ7749	FJ7749	71	1/4"-20NC Flanged Locknut	40641	40641
37b	1/4"-20NC Zinc Hex Nut	40627	40627	72	3/8"-16NC x 3/8" Lg. Flanged HHCS	40122	40122
				73	Actuator Pin Handle	FJ7985-1	FJ7985-1
				74	Sheave cover & (1) 1/4"-20 PHMS x 3/8" Lg. Plated	N119-1 40063	N119-1 40063
				75	3/4" Spacer	FJ7871	FJ7871
				76@@	3 Phase Limit Switch Assy. For Units Using Above 250V.	FJ7979	FJ7979
				77	Single Phase Limit Switch (only)	P461-2	P461-2
				78 ▲	Three Phase Limit Switch (only)	FJ7979-1	FJ7979-1
				79	Limit Switch Bracket Cover	FJ7979-2	FJ7979-2
				80	1/4" External Tooth Lockwasher	40779	40779
				81	3/8" External Tooth Lockwasher	40845	40845
				82 **	Arm Restraint Kit (1 Arm)	FJ7888	FJ7888

### Wheel Spotting Dish

Left Front Arm

Right Front Arm

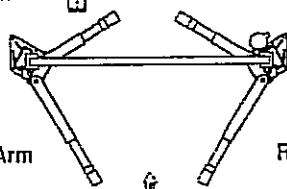

Left Rear Arm

Right Rear Arm

† Adjustment bolt, spring washer(s) and SAE washer(s) determined at assembly. Used only if required.

Bolt - 5/16"-18NC x 5/8" Lg. SHCS  
Spring Lock Washer - .078" thick  
SAE Washer - 11/32" I.D. x 11/16" O.D. x 1/16" thick

\* Includes item No#'s  
19, 20, 22, 23 & 24

\*\* Includes item No#'s  
34, 35, 36, 37, 38, 39,  
40, 41, 42 & 73

@@ Includes item 62, 79 & 80

▲ For units using above 250V, 250V and lower use P461-2 switch.

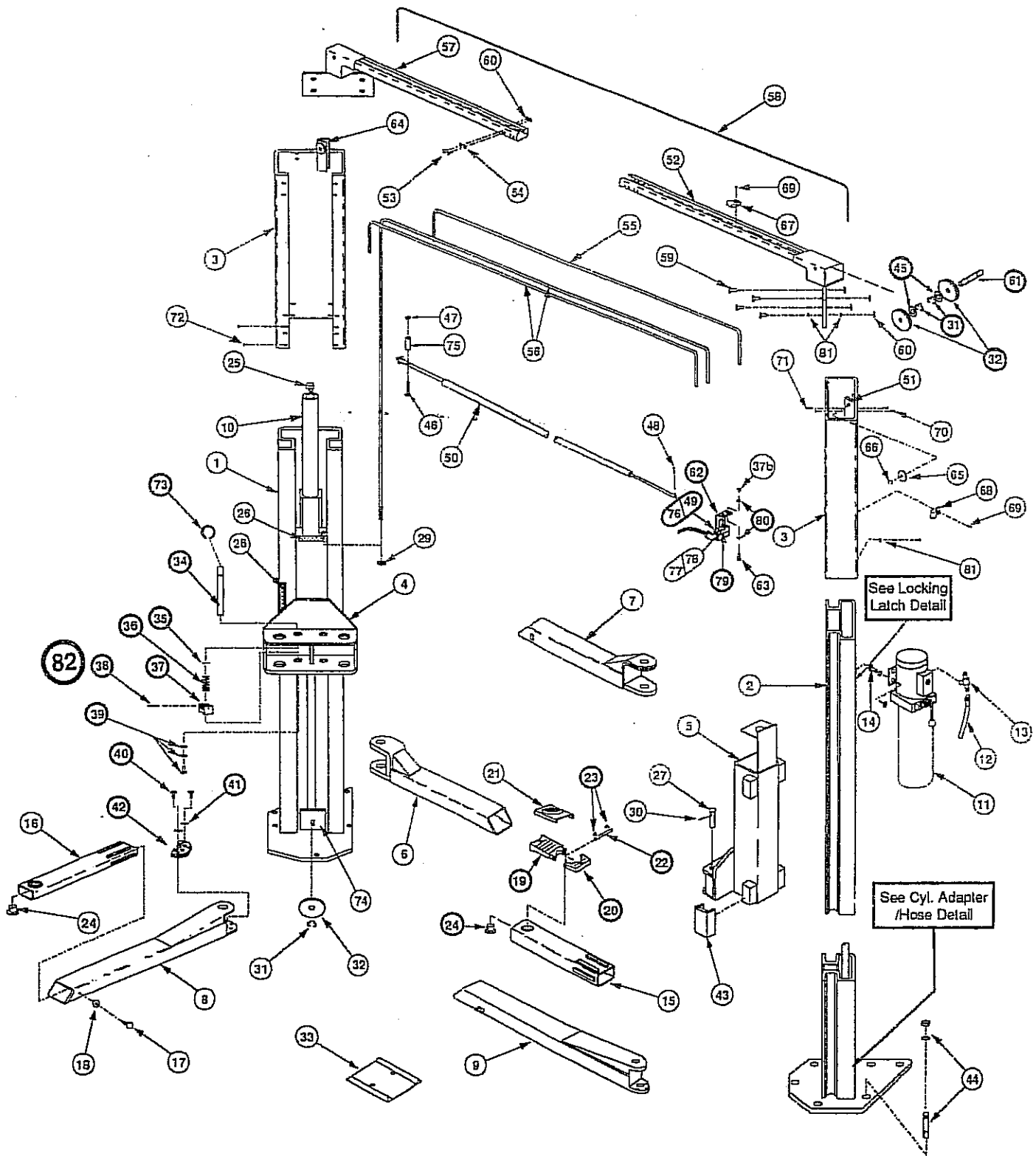

For Extended Height Models Use Part Numbers Below As Cross Reference, All Other Parts Are Common

	#3-Column Extensions	#55-Overhead Hose	#56-Equalizer Cables	#58-Locking Latch Cable
SPOA7 EH-1	N46	FJ840	FJ7545	FJ7595-1
SPOA7 EH-2	N47	FJ841	FJ7546	FJ7595-1
SPOA9 EH-1	N46	FJ842	N34	FJ7595-1
SPOA9 EH-2	N47	FJ843	N35	FJ7595-1

# CYLINDER ADAPTER / HOSE DETAIL

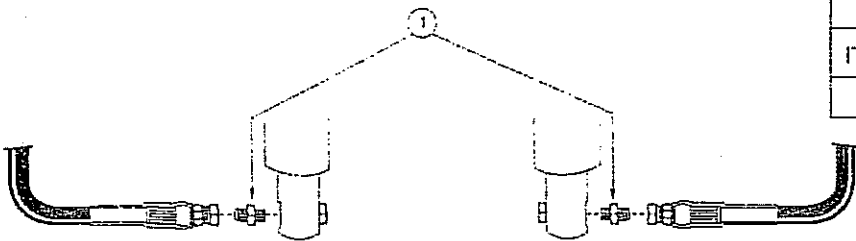

CYLINDER ADAPTER/HOSE DETAIL PARTS LIST		
ITEM NO.	DESCRIPTION	PART NO.
1	Straight Adapter	FJ7352-3

## RIGHT COLUMN

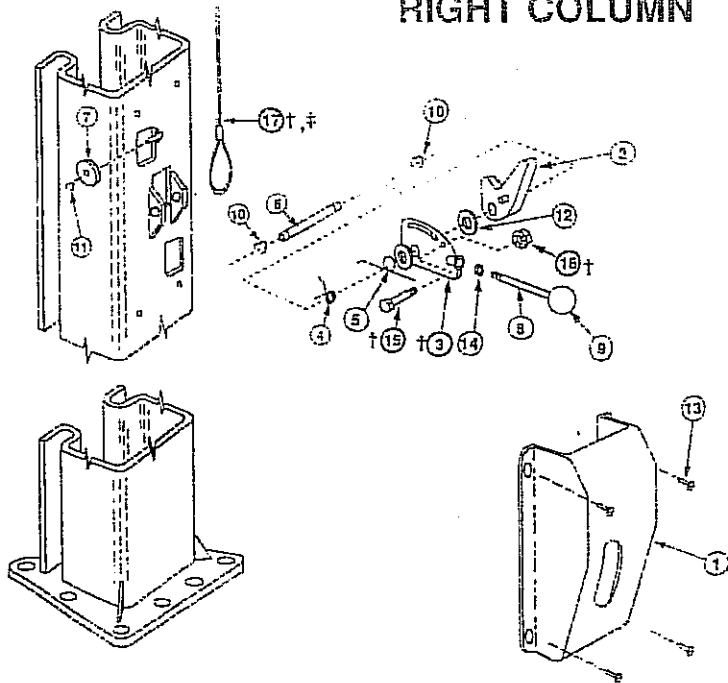

LOCKING LATCH DETAIL PARTS LIST		
ITEM NO.	DESCRIPTION	PART NO.
1	Control Side Cover	FJ7452
2	Locking Latch Dog	FJ7382-7
3	Control Plate	FJ7594-2
4	Spring	FJ7566-10
5	Spring	FJ7382-9
6	Latch Shaft	FJ7382-34
7	Locking Latch Sheave	FJ7322
8	Handle	FJ7382-18
9	Ball Handle	FC134-91
10	Truarc Klipring #5304-75 for 3/4" Shaft	41411
11	Truarc Klipring #5304-37 for 3/8" Shaft	41410
12	1 1/2" O.D. x 3/4" I.D. x .045" Mach. Bush.	41388
13	5/16" — 18NC x 3/8" Lg. Slotted Pan Hd. Screw	40227
14	3/8" - 16NC Hex Jam Nut	40658
15 †	Shoulder Bolt, 5/16" x 1" - 1/4" 20 NC	40220
16 †	Flanged Locknut, 1/4" - 20 NC	41423
17 †	Latch Cable	FJ7594-1
‡	For EH-1 & EH-2 Models Both OA7 & 9	FJ7595-1

† Locking Latch Retrofit Kit FJ7594; FJ7595 (EH-1 & 2)  
Includes: 1 pc. #3, 1 pc. #17, 2 pcs. #15, 2 pcs #16,  
1 pc. #3 (left side below), 1 pc. #15 (left side below)

## LEFT COLUMN

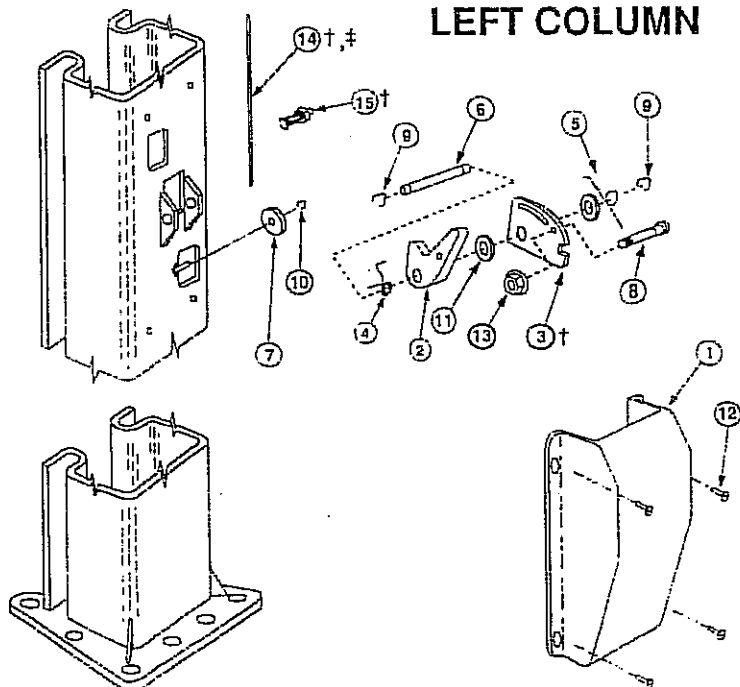

LOCKING LATCH DETAIL PARTS LIST		
ITEM NO.	DESCRIPTION	PART NO.
1	Latch Cover	FJ7451
2	Locking Latch Dog	FJ7382-7
3 †	Control Plate	FJ7382-5
4	Spring	FJ7566-10
5	Spring	FJ7382-9
6	Latch Shaft	FJ7382-34
7	Locking Latch Sheave	FJ7322
8	Shoulder Bolt 5/16" x 1" - 1/4" - 20NC	40220
9	Truarc Klipring #5304-75 for 3/4" Shaft	41411
10	Truarc Klipring #5304-37 for 3/8" Shaft	41410
11	1 1/2" O.D. x 3/4" I.D. x .045" Mach. Bush.	41388
12	5/16" — 18NC x 3/8" Lg. Slotted Pan Hd. Screw	40227
13	Flanged Locknut, 1/4" - 20 NC	41423
14	Latch Cable	FJ7594-1
15	Latch Cable Clamp (BURNDY)	KS-15
‡	For EH-1 & EH-2 Models Both OA7 & 9	FJ7595-1

† Locking Latch Retrofit Kit FJ7594; FJ7595 (EH-1 & 2)  
(see Right Column for items included)



ROTARY LIFT  
A Dover Industries Company  
P.O. Box 1560  
Madison, Indiana 47250-0560  
Phone toll-free: 1-800-445-LIFT (5432)  
(300) 822-6502  
FAX: (317) 273-3404

For Export  
ROTARY LIFT EXPORT  
COMPANY  
200 Excelsior Drive, Suite 300  
West Orange, NJ 07052  
(201) 325-3535  
Telex # 13-8699  
FAX: (201) 325-7574

For Canada:  
DOVER CORPORATION CANADA -  
ROTARY LIFT DIVISION  
130 Bridgeland Avenue, Unit 210  
Toronto, Ontario, Canada M6A 1Z4  
(416) 256-4100  
FAX: (416) 256-3924